

ART. 7000

VALVOLA DI INTERCETTAZIONE GAS LIQUIDO DIRITTA M., PORTAGOMMA PER TUBO CON Ø INTERNO 8 mm (UNI 7140)

LIQUID GAS STRAIGHT CUT OFF VALVE M., HOSE CARRIER FOR PIPE WITH INSIDE Ø 8 mm (UNI 7140)

airagas **valve** 

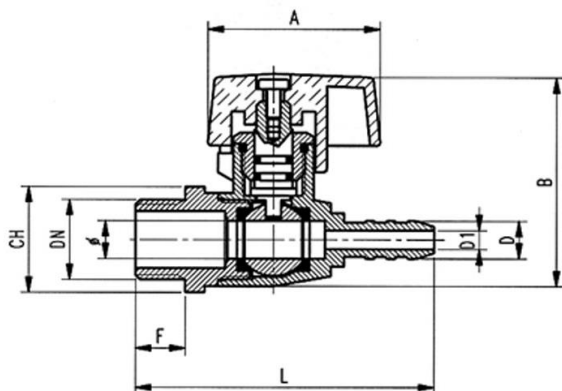

IMPIEGHI - USES

Airaga Rubinetterie S.p.A. progetta, produce e collauda le valvole a sfera per gas serie 7000 adottando un sistema di qualità secondo le norme UNI EN 9001:2015. Vengono utilizzate in impianti a gas a bassa pressione per la prima, seconda e terza famiglia (EN 437).

Airaga Rubinetterie S.p.A. designs, produces and certifies ball valves for gas range 7000, adapting a quality system in accordance with the Standards UNI EN ISO 9001:2015. They are used in low pressure gas systems for the first, second and third family (EN 437)

MATERIALI E CARATTERISTICHE – MATERIALS AND FEATURES

Corpo e maniccotto: stampati a caldo da barra EN12165 CW617N, nichelati.

Asta di comando e premistoppa: lavorata da barra EN12164 CW617N.

Sfera: tornita da barra EN12164 CW617N, diamantata e cromata a spessore.

Guarnizioni di tenuta sfera: P. T. F. E.

Guarnizione asta e premistoppa: nr. 3 O-Rings in NBR.

Farfalla di manovra: pressofusa in lega di alluminio UNI EN 1706, sabbiata e rivestite con vernici epossidiche.

Vite: UNI 5739, acciaio zincato.

Attacchi filettati: filettature UNI ISO 228/1

Sigillante per filettature: adesivo anaerobico tipo "Loctite".

Trattamento esterno valvola: superficie esterna nichelata brillante.

Body and sleeve: hot moulded from EN12165 CW617N bar, nickel plated.

Gland and Stem: worked from EN12164 CW614N bar.

Ball: turned from EN12164 CW617N bar, diamond and chrome plated.

Ball gaskets: P. T. F. E.

Stem gaskets: nr.3 O-Rings NBR.

Operating lever: die cast or melted in aluminium alloy UNI EN 1706, sandblasted and coated with epoxidic paints.

Screw: UNI 5739-galvanized steel.

Threaded connections: UNI ISO 228/1 threads.

Seal for threads: "Loctite" type anaerobic adhesive.

External treatment: brilliant nickel plated surface.

CONDIZIONI DI ESERCIZIO – WORKING CONDITIONS

Temperatura di esercizio: limite di servizio da -20 °C a +60 °C.

Massima pressione operativa (MOP): 5 bar (0,5 Mpa).

Working temperature: service limit from -20 °C to +60 °C.

Maximum Operating Pressure (MOP): 5 bar (0,5 Mpa).

ART.	7000/03	7000/04
DN e pass. mm	3/8" (10)	1/2" (10)
B	55	55
F	12	13
A	45	45
CH	21	25
D	9	9
D1	5	5
L	76	78,5
Peso (Weight) g.	190	190