

ART. 681

VALVOLA A SFERA A PASSAGGIO TOTALE ATTACCHI F.F. CON MANIGLIA A LEVA ALLUMINIO ROSSA FILETTATURA EN 10226

BALL VALVE FULL BORE F.F. WITH RED ALUMINIUM LEVER HANDLE THREAD EN 10226

heavyvalve



IMPIEGHI - USES

Airaga Rubinetterie S.P.A produce e collauda le valvole a sfera art. 681 adottando un sistema di qualità secondo le norme UNI EN ISO 9001:2015. Vengono utilizzate principalmente in impianti idraulici domestici e commerciali, applicazioni industriali ed agricole, impianti di riscaldamento, idrici, igienico-sanitari, aria compressa, reti di distribuzione olii, benzine, vapore saturo, servizi di acqua calda, linee di condensa, petrolio e altri idrocarburi, generalmente con ogni fluido compatibile non corrosivo, a media ed alta pressione.

Airaga Rubinetterie spa produces and tests ball valves range 681 according to a quality system UNI EN ISO 9001:2015. They are mainly used in: domestic and commercial hydraulic plants, agricultural and industrial systems, heating systems, waterworks, compressed air, oil distribution networks, gasoline, saturated steam, hot water, condensate lines, oil and other hydrocarbons, generally with every other compatible non corrosive fluid, with medium and high pressure.

MATERIALI E CARATTERISTICHE – MATERIALS AND FEATURES

Corpo e manicotto: stampati a caldo da barra EN12165 CW617N fino al 2", 2"1/2, 3" e 4" fusi in ottone EN1982, nichelati.

Premistoppa e asta di comando: lavorati da barra EN12164 CW617N.

Sfera: 1/4" e 3/8" tornita da barra EN12164 CW617N, dal 1/2" al 1"1/4 stampata da barra EN 12165 CW617N, dal 1"1/2 al 4" fusa in ottone EN1982, diamantata e cromata a spessore.

O-ring asta: EPDM 4270 per le misure dal 1/2" al 2".

Guarnizioni di tenuta sfera: P.T.F.E.

Guarnizione asta: P.T.F.E.

Leva di manovra: pressofusa o fusa in lega di alluminio UNI EN 1706 sabbiata e rivestita con vernici epossidiche.

Vite: UNI 5739 - acciaio zincato.

Attacchi filettati: Attacchi filettati: filettature EN 10226 - A richiesta: ISO 228/1 (Cilindrica) - ANSI B.1.20.1 (NPT).

Sigillante per filettature: adesivo anaerobico tipo "Loctite".

Trattamento esterno valvola: superficie nichelata brillante.

Body and sleeve: hot moulded from EN12165 CW617N bar until 2", 2"1/2, 3" and 4" hot melted in brass EN1982, nickel plated.

Gland and stem: worked from EN12164 CW617N bar.

Ball: 1/4" and 3/8" turned from EN12164 CW617N bar, from 1/2" to 1"1/4 hot moulded from EN12165 CW617N bar, from 1"1/2 to 4" melted in brass EN1982, diamond and chrome plated.

O-ring stem: EPDM 4270 for sizes from 1/2" to 2".

Ball gaskets: P.T.F.E.

Stem gasket: P.T.F.E.

Operating lever: die cast or melted in aluminium alloy UNI EN 1706, sandblasted and coated with epoxidic paints.

Screw: UNI 5739 - galvanized steel.

Threaded connections: EN 10226 - On request: ISO 228/1 (Cylindric), ANSI B.1.20.1 (NPT) threads.

Seal for threads: "Loctite" type anaerobic adhesive.

External treatment: brilliant, nickel plated surface.

CONDIZIONI DI ESERCIZIO – WORKING CONDITIONS

Temperatura di esercizio: limite di servizio da -20 °C a +120 °C.

Working temperature: service limit from -20 °C to +120 °C.

Pressione massima di esercizio | Maximum working pressure

DN	PN
1/4" - 3/8" - 1/2"	60
3/4" - 1"	40
1"1/4	25
1"1/2-2"-2"1/2 - 3" - 4"	16

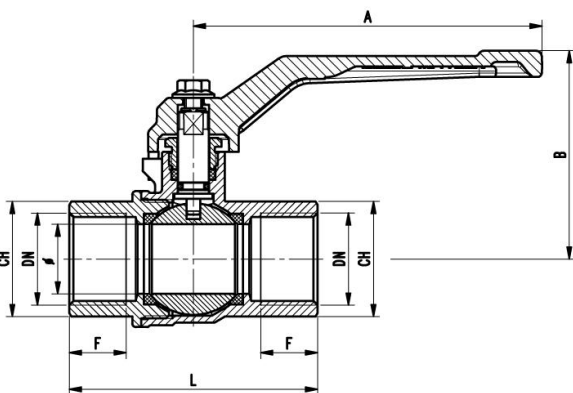

ART.	0681/02-R	0681/03-R	0681/04-R	0681/05-R	0681/06-R	0681/07-R	0681/08-R	0681/09-R	0681/10-R	0681/11-R	0681/13-R
DN e pass. mm	1/4" (10)	3/8" (10)	1/2" (15)	3/4" (20)	1" (25)	1"1/4 (32)	1"1/2 (40)	2" (50)	2"1/2 (60)	3" (74)	4" (94)
L	46,5	46,5	62	71	81,5	92	102	126	146	163	195
B	42	42	48	52	64	71	84	90	125,5	140	168,5
F	10	10	15	16,3	19,1	21,4	21,4	26	29	29	32
CH	21	21	26	31	38	48	55	68	89	100	127
A	87	87	100	100	110	110	140	140	194	194	127
Peso (Weight) g.	130	105	230	315	540	835	1260	1900	4560	6560	8000